

SFP-OC3-CX

Copper OC-3 SFP Transceiver

Product Overview



SFP-OC3-CX

Overview

The SFP-OC3-CX module is a Small Form-factor Pluggable (SFP) module that offers easy full-duplex interfacing with 155 Mbps OC-3 electrical interfaces (STM-1e, ES1) over 75Ω telecommunications coaxial cable. It includes Clock and Data Recovery (CDR) in both directions, and a CMI encoder/decoder for transparent NRZ-to-CMI line code conversion. It provides Loss of Signal (LOS) detection for electrical CMI interfaces and the option to disable the transmit driver to support the Link Integrity Notification (LIN) feature on applicable MRV modules. A serial interface provides access to an on-board EEPROM for identification information including manufacturer, part number, serial number, and date code.

The SFP-OC3-CX complies with Multi-Source Agreement SFF-8472 for SFP transceivers.

Applications

Typical applications include SDH multiplexer systems or ATM switch and IP-router equipment supporting SDH physical interfaces. The SFP-OC3-CX module is fully interchangeable with STM-1 and OC-3 optical SFP transceivers, offering system developers an easy migration to STM-1 electrical interfaces. Any system that already supports the STM-1 optical SFP also supports the STM-1 electrical SFP. This modular flexibility minimizes development efforts and time-to-market for STM-1 solutions because a single card design supports both optical and electrical STM-1 interfaces.

Features

- MSA compliance for SFP transceivers (SFF-8472)
 - Detection for Loss-of-Signal (ITU-T G.783)
 - Control for transmit power down*
 - Handles over 12.7 dB of cable loss
 - Extended temperature operation: -20 C to 85 C
 - 75Ω media interface compliance for CMI coded 155 Mbps electrical interfaces
 - ITU-T G.703
 - Telcordia GR-253
 - 75Ω DIN 1.0/2.3 female coaxial interface for Type A and Type D coupling
 - Low power dissipation (0.6 W typical)
 - RoHS 5/6 compliance
- * LIN support for applicable MRV modules

Benefits

- Provides end user flexibility through independent port configuration
- Reduces deployment cost for STM-1 electrical interfaces

Transceiver Functional Diagram

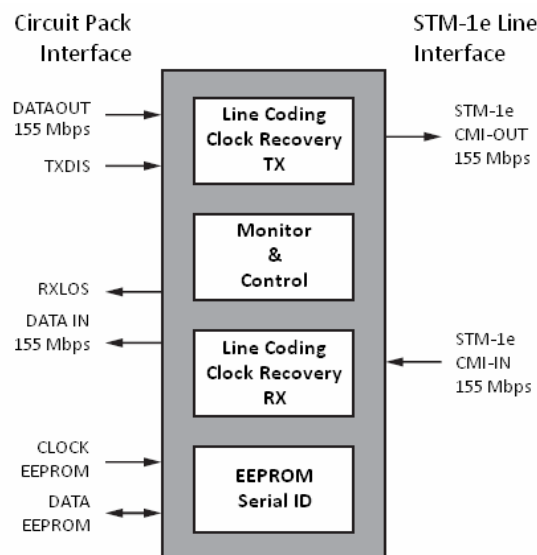

Serial ID Interface

The SFP-OC3-CX supports the 2-wire serial EEPROM protocol for the ATMEL AT24C02, as defined by the MSA for access to identification information. The memory is organized as byte-wide data that can be addressed individually or sequentially at device address 1010000X (A0h).

Receiver Specifications

Parameter	Value
Cable Flat-Loss Tolerance	0 to 12.7 dB
Latency	5 to 10 UI
DLL Lock Time	1 to 10 μ s
Return Loss	7MHz to 240MHz 15 dB min
Input Signal	Must comply with ITU-T G.703

Transmitter Specifications

Parameter	Value
Bit Rate	155.52 Mbps \pm 20 ppm
Line Code	Coded Mark Inversion (CMI)
Relevant Specification	ITU-T G.703, ANSI T1.102, Telcordia GR-253-CORE

With the coaxial output port driving a 75 Ω load, the output pulses conform to the templates in ITU-T G.703 and G.783.

Transmitter Specifications

Parameter	Value
Peak-to-peak Output Voltage Template	Steady state 0.9 to 1.1 V
Rise/ Fall Time	10-90% 2 ns
Transition Timing Tolerance	Transitions at mid-interval -0.35 to +0.35 Ns
Return Loss	7MHz to 240MHz 15 dB min

Environmental and Regulatory Compliance

Parameter	Value
ESD threshold	1KV at faceplate*
Radiated Emission	FCC Part 15 Class B EN55022, CISPR 22 (6db margin)
Radiated Immunity	Class A per IEC-801-3, EN55082-1, IEC-61000-4-3, GR-1089
Component Recognition	CSA C22.2, UL 60950-1
Shock and Vibration	0.2 G p-p, 9 – 62 Hz
Flammability	94V0

* Varies with system design.

Ordering Information

Model	Description	Protocol	Connectors	Impedance	Maximum Cable Length	Operating Temperature Range
SFP-OC3-CX	Copper SFP Transceiver	OC-3	Coax 1.0/2.3 BNC	75 Ohms	100 Meters	-20 to 85 °C

Ordering Information: ACCESSORIES

Model	Description
1600125-001R	Coax cables, 2 used with SFP

Source: Product Datasheet from MRV Manufacturer

About Cell Technology

Cell Technology headquartered at Hong Kong SAR, a network & security technology provider specializes in design, develop and deliver innovative and intelligent IP packet processing platform into software and hardware appliances. Cell product solutions including Cell IPS, UTM, CMC, Janus, TMS, NetsVision and NetsAccess address the business needs that optimize the IP network performance, secure the network security and resiliency, and manage the quality of IP services. For more information, please visit www.cell-technology.net.